

# MUSKET

## Regressed Fixed LED Downlight

40124.10

### TECHNICAL DATA



**Luminaire:** Illuminance: 255 Lux @ 2.7m  
Beam Angle: 30°  
Ingress Protection: IP65  
Material: Die-Cast Aluminium  
Finish: Matt White Bezel and Black Inner Baffle

**LED Driver:** Input: 230Vac 0.050A 11W p.f. >0.9  
Output: 260mA 24-46Vdc  
Electrical Safety: Class II Pre-Wired Input Cable  
Mains Dimmable with Leading or Trailing Edge Dimmers

**Light Engine:** Luminous Flux: 900 Lumens  
Colour Temperature (CCT): 3000K (Warm White)  
Colour Consistency: 2-Step MacAdam Ellipse  
Colour Rendering (CRI): >95 Ra >90 Re  
Efficacy: 82 Lumens per Circuit Watt  
Lumen Maintenance: L70 >60,000Hrs  
Reflector: 40°

**Miscellaneous:** Weight: 340g (Luminaire + LED Driver)

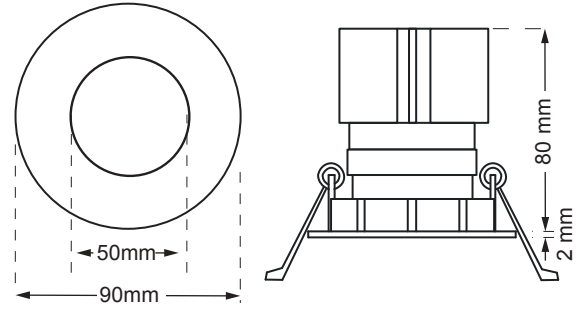

Measurements obtained from Spectroradiometer LT-SM999 and Spectrometer ALP-01

Designed in  
London by  
Flairlight

### INSTALLATION

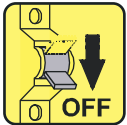

Isolate electrical supply before undertaking any electrical work.  
Installation must comply with the current wiring and building regulations.



**MADE IN BRITAIN**

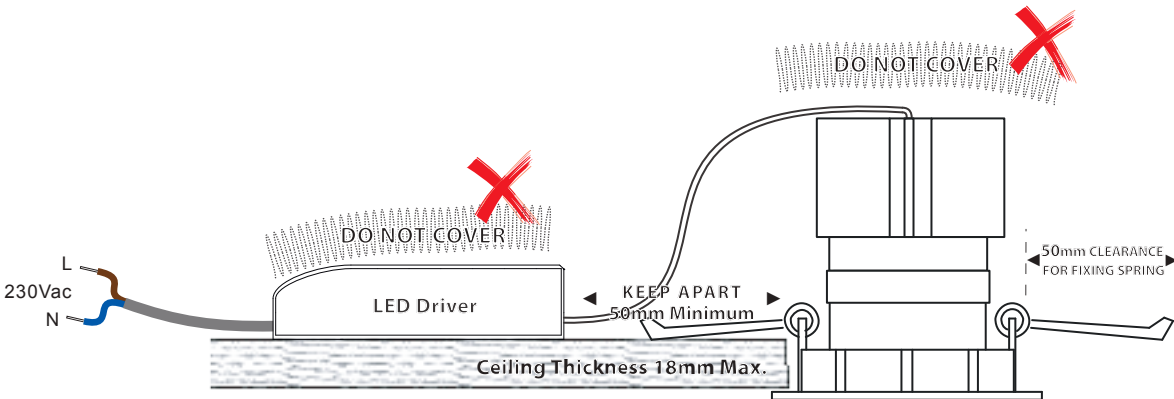

**Energy Efficiency Index**

**Flairlight 40124.10**

11kW/1000h  
874/2012

### Symbol Key

- Class I Electrical Safety - Earthed Metalwork
- Class II Electrical Safety - Double Insulated, Earth Not Necessary
- Class III Electrical Safety - S.E.L.V. (Safety Extra Low Voltage), Voltage Less Than 48V
- Dimmable (Not Dimmable if Crossed)
- Suitable for Mounting on Normally Flammable Material (e.g. Wood)
- Ingress Protection - 1st Digit: Solid Object Rating, 2nd Digit: Water Rating

